

LUNA-TIMER-BIANCA

8025431152915

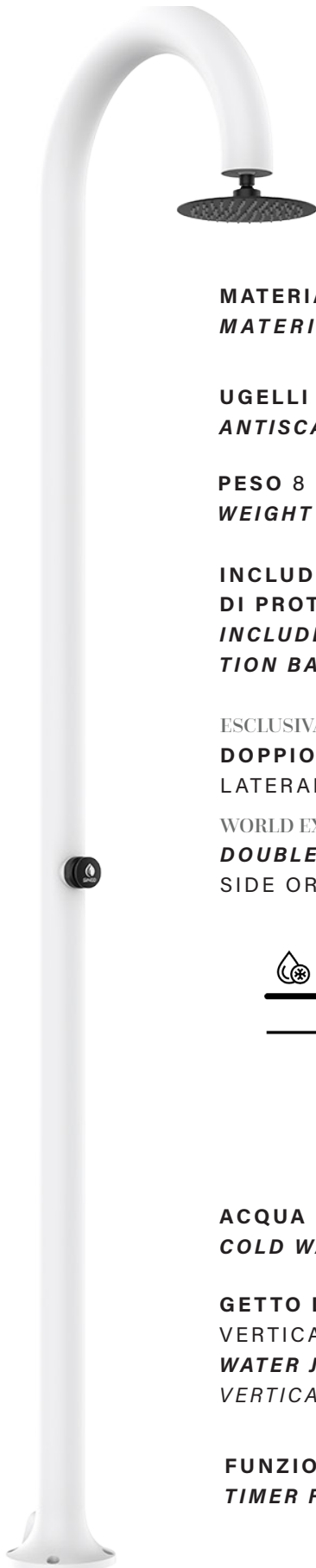

MATERIALE ALLUMINIO
MATERIAL ALUMINUM

ACCESSORI ACCIAIO INOX 304
ACCESSORIES STAINLESS STEEL 304

UGELLI ANTICALCARE
ANTISCALE NOZZLES

DUE FILTRI ANTICALCARE INCLUSI
TWO ANTI-SCALE FILTERS INCLUDED

PESO 8 KG
WEIGHT 8 KG

FILTRO ANTICALCARE INCLUSO
FILTER LIMESCALE INCLUDED

INCLUDE UNA SACCA
DI PROTEZIONE
INCLUDES A PROTEC
TION BAG



PRODOTTO IN DUE
PARTI. SCATOLA FAC-
ILE DA MANEGGIARE
PRODUCT IN TWO-
PARTS EASY-TO-HAN-
DLE BOX

ESCLUSIVA MONDIALE!
DOBPIO INGRESSO ACQUA
LATERALE O INFERIORE

WORLD EXCLUSIVE!
DOUBLE WATER INLET
SIDE OR BOTTOM

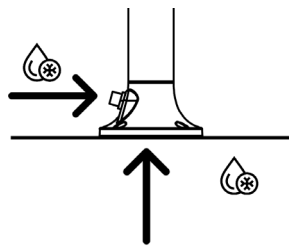

ACQUA FREDDA
COLD WATER



GETTO D'ACQUA
VERTICALE
WATER JET
VERTICAL



FUNZIONE TIMER
TIMER FUNCTION

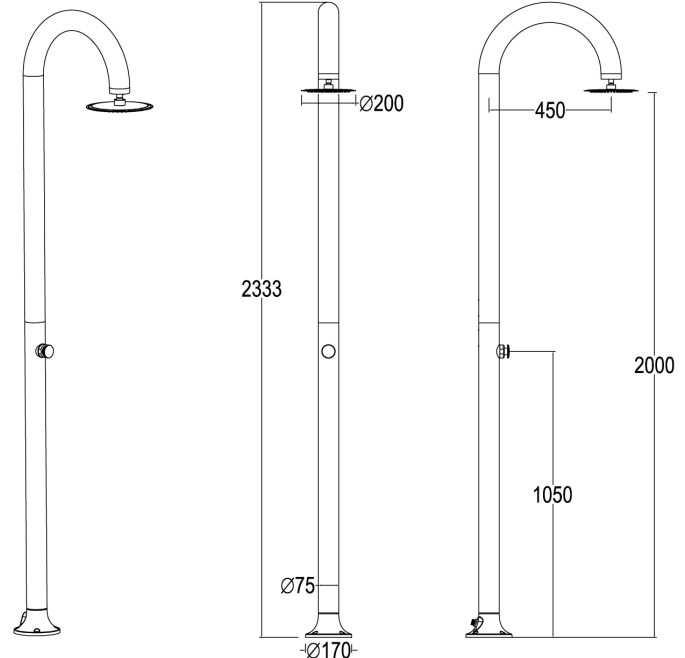

(mm)

